

QCW520

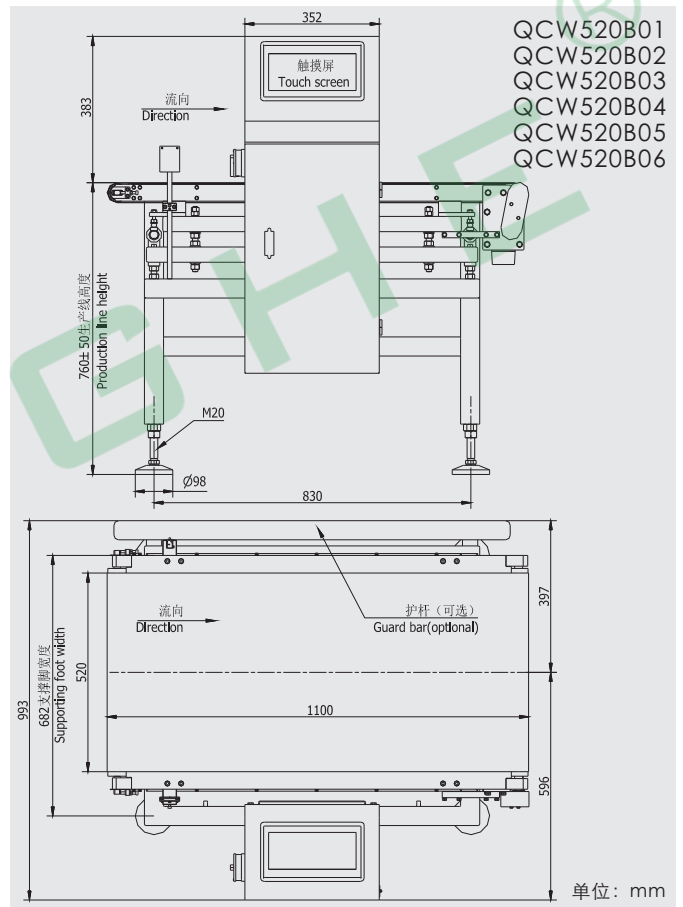

QINSHI®

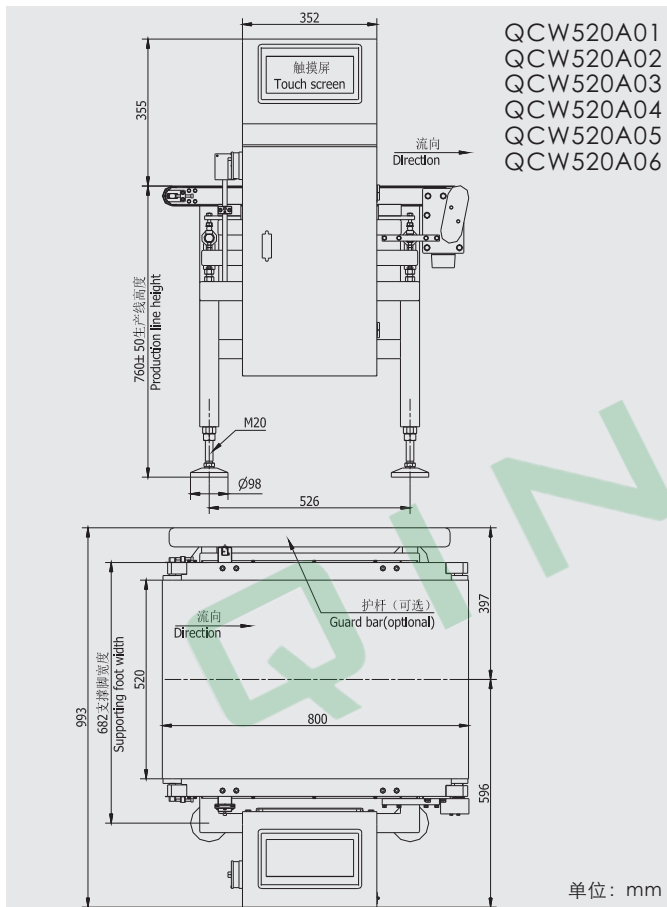

QCW520



推选剔除
Push type rejector

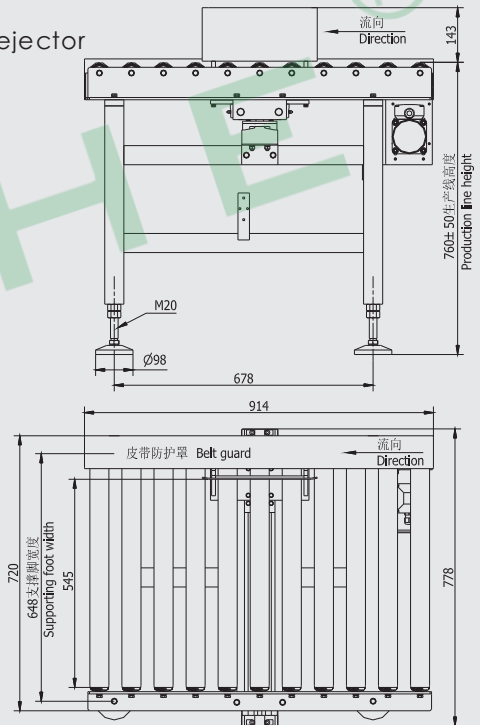

单位: mm

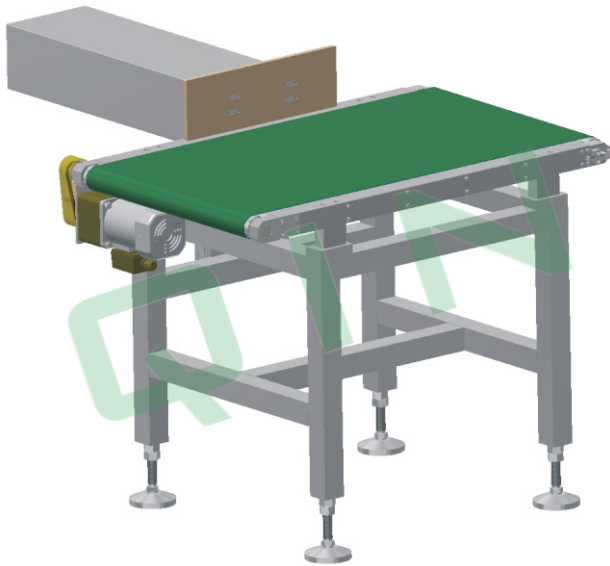

推选剔除
Push type rejector

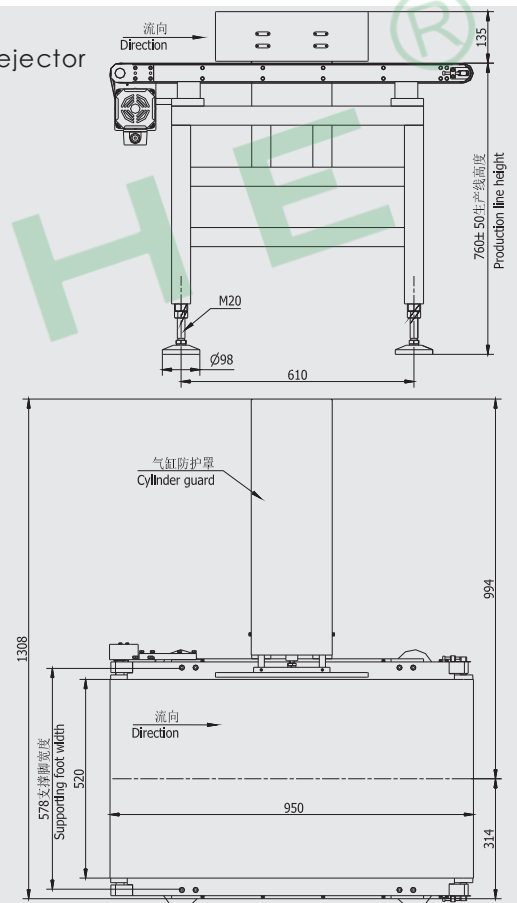

单位: mm

技术规格 Specifications

型号Model	QCW520A01	QCW520A02	QCW520A03	QCW520A04	QCW520A05	QCW520A06
传感器量程 Loadcell Capacity	4×50kg	4×100kg	4×50kg	4×100kg	4×50kg	4×100kg
称重范围Capacity	100~25000g	200~40000g	100~25000g	200~40000g	100~25000g	200~40000g
显示分度Resolution	1g	2g	1g	2g	1g	2g
最高选别精度(3σ)* Accuracy(3σ)	±5g	±10g	±5g	±10g	±5g	±10g
最高选别能力* Throughput	32~52pcs/min		26~43pcs/min		18~30pcs/min	
显示操作方式 Display	10#彩色触摸屏 10# color touch screen					
产品数量 Number of items	199种 199 items					
分选段数 Sorting section	2段 2 sections					
分选类别 Sorting type	推杆式 Push type rejector					
被测品 Product	长Length	110~650mm				
	宽Width	5~500mm				
	高Height	5~650mm				
输送段速度 Conveyor belt speed	16~50m/min		14~41m/min		11~30m/min	
	调速方式: 变频器无级调速, 在触摸屏上操作 Speed control mode: Inverter stepless speed regulation, operation on touch screen					
一般技术规格 General specifications	<p>电源: 标配单相AC200~240V, 50/60Hz, 0.4kw, 可选三相AC380V,50/60Hz, 0.4kw 气源: 干燥的0.5~0.7MPa(5~7bar) 温度: 使用温度: 0℃~40℃, 储存温度: -20℃~60℃ 湿度: 10~90%RH, 无冷凝 防护等级: IP30 噪声: ≤75db 机器重量: 约60kg 工作高度: 760±50mm (其它高度订货时确定) Power supply: Standard Single phase AC200~240V, 50/60Hz, 0.4kw Optional three phase AC380V,50/60Hz, 0.4kw Air supply: Dry 0.5~0.7MPa(5~7bar) Temperature: Operation temperature: 0℃~40℃, Storage temperature: -20℃~60℃ Humidity: 10~90%RH, no condensation Protection level: IP30 Noise: ≤75db Machine weight: Approx. 60kg Conveyor height: 760±50mm (Other height can be determined when ordering)</p>					
材质 Material	<p>称重传感器: 不锈钢 电气柜: 不锈钢304 滚筒: 不锈钢304 输送机框架: 铝 结构: 不锈钢304 输送皮带: 绿色, 食品级, 聚氨脂热塑性塑料(TPU) Load cell: Stain steel Electrical cabinet: Stain steel 304 Roller: Stain steel 304 Conveyor frame: Aluminum Structure: stainless steel 304 Conveyor belt: Green, food grade, thermoplastic polyurethane (TPU)</p>					

*最高选别能力和精度, 根据实际被测品、选别部和安装环境的不同而有所不同。

*Depends on the shape and rejector and the condition of the product and installation environment.

技术规格 Specifications

型号Model	QCW520B01	QCW520B02	QCW520B03	QCW520B04	QCW520B05	QCW520B06
传感器量程 Loadcell Capacity	4×50kg	4×100kg	4×50kg	4×100kg	4×50kg	4×100kg
称重范围Capacity	100~25000g	200~40000g	100~25000g	200~40000g	100~25000g	200~40000g
显示分度Resolution	1g	2g	1g	2g	1g	2g
最高选别精度(3σ)* Accuracy(3σ)	±5g	±10g	±5g	±10g	±5g	±10g
最高选别能力* Throughput	22~38pcs/min		18~31pcs/min		12~27pcs/min	
显示操作方式 Display	10#彩色触摸屏 10# color touch screen					
产品数量 Number of items	399种 399 items					
分选段数 Sorting section	2段 2 sections					
分选类别 Sorting type	推杆式 Push type rejector					
被测品 Product	长Length	110~950mm				
	宽Width	5~500mm				
	高Height	5~950mm				
输送段速度 Conveyor belt speed	16~50m/min		14~41m/min		11~30m/min	
	调速方式: 变频器无级调速, 在触摸屏上操作 Speed control mode: Inverter stepless speed regulation, operation on touch screen					
一般技术规格 General specifications	电源: 标配单相AC200~240V, 50/60Hz, 0.4kw, 可选三相AC380V,50/60Hz, 0.4kw 气源: 干燥的0.5~0.7MPa(5~7bar) 温度: 使用温度: 0℃~40℃, 储存温度: -20℃~60℃ 湿度: 10~90%RH, 无冷凝 防护等级: IP30 噪声: ≤75db 机器重量: 约60kg 工作高度: 760±50mm (其它高度订货时确定) Power supply: Standard Single phase AC200~240V, 50/60Hz, 0.4kw Optional three phase AC380V,50/60Hz, 0.4kw Air supply: Dry 0.5~0.7MPa(5~7bar) Temperature: Operation temperature: 0℃~40℃, Storage temperature: -20℃~60℃ Humidity: 10~90%RH, no condensation Protection level: IP30 Noise: ≤75db Machine weight: Approx. 60kg Conveyor height: 760±50mm (Other height can be determined when ordering)					
材质 Material	称重传感器: 不锈钢 电气柜: 不锈钢304 滚筒: 不锈钢304 输送机框架: 铝 结构: 不锈钢304 输送皮带: 绿色, 食品级, 聚氨脂热塑性塑料(TPU) Load cell: Stain steel Electrical cabinet: Stain steel 304 Roller: Stain steel 304 Conveyor frame: Aluminum Structure: stainless steel 304 Conveyor belt: Green, food grade, thermoplastic polyurethane (TPU)					

*最高选别能力和精度, 根据实际被测品、选别部和安装环境的不同而有所不同。

*Depends on the shape and rejector and the condition of the product and installation environment.