

# QCW250

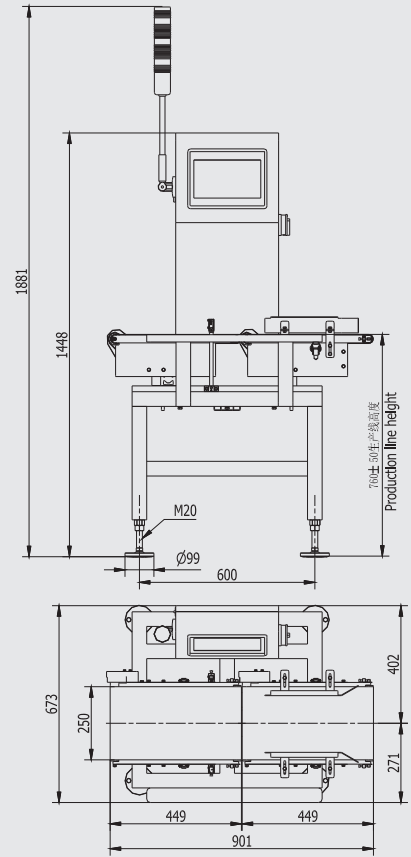

QCW250A01  
QCW250A02



单位: mm



推选剔除  
Push type rejector

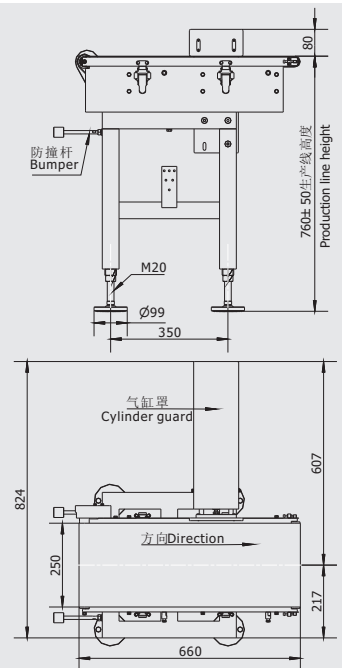

单位: mm

## 技术规格 Specifications

型号Model	QCW250A01	QCW250A02
传感器量程 Loadcell Capacity	20kg	50kg
称重范围Capacity	10~1000g	20~2000g
显示分度Resolution	0.1g	0.5g
最高选别精度(3σ)* Accuracy(3σ)	±0.4g	±2g
最高选别能力* Throughput	75~180pcs/min	
显示操作方式 Display	10#彩色触摸屏 10# color touch screen	
产品数量 Number of items	199种 199 items	
分选段数 Sorting section	标准2段, 可选3段 Standard 2 sections, optional 3 sections	
分选类别 Sorting type	推杆式 Push type rejector	
被测品 Product	长Length	70~300mm
	宽Width	5~230mm
	高Height	5~130mm
输送段速度 Conveyor belt speed	36~110m/min, 调速方式: 变频器无级调速, 在触摸屏上操作 Speed control mode: Inverter stepless speed regulation, operation on touch screen	
一般技术规格 General specifications	电源: 标配单相AC200~240V, 50/60Hz, 0.4kw, 可选三相AC380V,50/60Hz, 0.4kw 气源: 干燥的0.5~0.7MPa(5~7bar) 温度: 使用温度: 0℃~40℃, 储存温度: -20℃~60℃ 湿度: 10~90%RH, 无冷凝 防护等级: IP30 噪声: ≤75db 机器重量: 约60kg 工作高度: 760±50mm (其它高度订货时确定) Power supply: Standard Single phase AC200~240V, 50/60Hz, 0.4kw Optional three phase AC380V,50/60Hz, 0.4kw Air supply: Dry 0.5~0.7MPa(5~7bar) Temperature: Operation temperature: 0℃~40℃, Storage temperature: -20℃~60℃ Humidity: 10~90%RH, no condensation Protection level: IP30 Noise: ≤75db Machine weight: Approx. 60kg Conveyor height: 760±50mm (Other height can be determined when ordering)	
材质 Material	称重传感器: 不锈钢 电气柜: 不锈钢304 滚筒: 不锈钢304 输送机框架: 不锈钢304 结构: 不锈钢304 输送皮带: 白色, 食品级, 聚氨脂热塑性塑料(TPU) Load cell: Stain steel Electrical cabinet: Stain steel 304 Roller: Stain steel 304 Conveyor frame: Stain steel 304 Structure: stainless steel 304 Conveyor belt: White, food grade, thermoplastic polyurethane (TPU)	

\*最高选别能力和精度, 根据实际被测品、选别部和安装环境的不同而有所不同。

\*Depends on the shape and rejector and the condition of the product and installation environment.